

MODEL 458ACB
FUNCTION GENERATOR
OPERATIONAL MANUAL

KIKUSUI ELECTRONICS CORP.

77429

771308 -

Alteration to MODEL 458ACB from MODEL 458A

1 Hz gate signal generator having duty ratio of 50% with general operation modes of MODEL 458A employs for CB transceiver testing. Tone burst waveform can be provided without any other instrument.

Alteration parts

- (1) 19 ~ 15 lines on page 5

Sync Signal Output	Output synchronizing with tone burst waveform (Approximately 1 Hz).
Level	TTL level. Fun-out 2.
Pulse width	Approximately 500 ms.

- (2) First line on page 6
 'EXT TRIG SLOPE' is changed to 'TRIG SLOPE'.

- (3) 11 ~ 18 lines on page 6
 18. SYNC OUTPUT Output terminal for gate signal synchronizing with tone burst waveform. Phase angle of gate signal can be changed 180° with the TRIG SLOPE switch 14..

- (4) Front panel Fig. 3-1 on page 7.

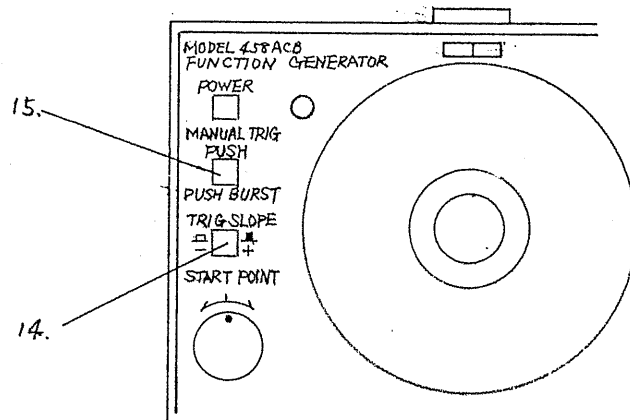

OPERATION

Example : 2.5 kHz, 500 ms repetition tone burst waveform

o Setting of knobs

- | | |
|-------------------------------|---|
| 1. FREQUENCY | 2.5 kHz |
| 2. FUNCTION |  |
| 3. MODE | EXT GATE |
| 4. MANUAL TRIG (PUSH BURST) | PUSH |
| 5. START | Center |
| 6. DC OFFSET | OFF |

o Gate signal synchronizing with tone burst waveform is provided on the SYNC OUTPUT terminal on the rear panel.

o Phase angle of synchronizing signal is changed 180° with the TRIG SLOPE switch.

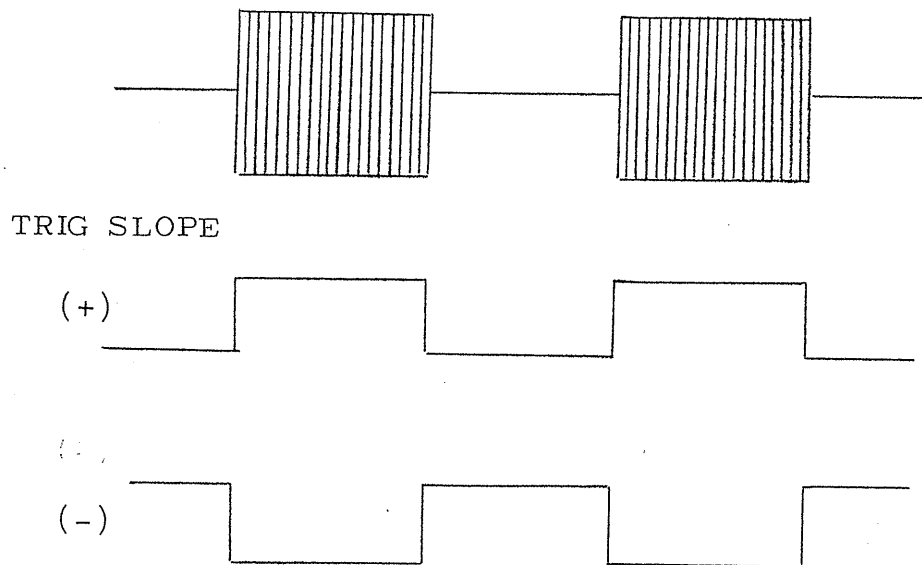

TABLE OF CONTENTS

1.	GENERAL DESCRIPTION	1
2.	SPECIFICATIONS	2
3.	OPERATIONS	4
3-1	Front Panel and Controls	4
3-2	Rear Panel Descriptions	6
4.	PRINCIPLE OF OPERATION	8
4-1	Fundamental Operation	8
4-2	VCG (Voltage control Generator) ...	9
4-3	Slope Control	10
4-4	DC offset	11
4-5	Triggering Oscillation	11
4-6	Gated Oscillation	13
5.	APPLICATION	14
5-1	In case of linear sweep from 100Hz to 100kHz at rated of 10 periods/sec.	14
5-2	In case of offset application	15
5-3	In case of generation of burst waveform	16
6.	ARRANGEMENT	17

1. GENERAL DESCRIPTION

KIKUSUI's MODEL 458A is a function generator which provides signal of sine-wave, triangular-wave, square-wave and variable slope sawtooth waveform 0.01Hz to 100kHz. Output voltage can be obtained max. 30Vp-p at open circuit, 15Vp-p with rated load 600Ω.

Oscillation frequency is variable with manual control divided in 7 ranges decade and also VCG function is employed, which has variable range of 1:1000.

Then the frequency is proportional to input voltage (10mV~ 10V).

A half period of triangular and square-wave is variable, if DC offset of output wave is required, it is easily obtained for all waveforms with offset control on front panel.

To control the start of oscillation, trigger function (generation of one cycle of waveform) and gated function (generation of tone burst waveform) are provided using external signal or manual operation. The phase at the start and stop of the oscillation frequency can also be varied within a range of zero to ± 90 degrees.

Model 458A can be used as a voltage control generator, tone burst generator for special waveforms as well as an ordinary generator. Therefore, it is widely applied to many types of measurements and tests such as frequency response measurement of feedback amplifiers, tests of servo equipment in automatic control systems, tests of analog computer, function generators, signal tests of vibration exciters and sound equipment.

771318

2. SPECIFICATIONS

Functions	1. Frequency Control 2. Oscillation Mode 3. DC offset	MANUAL or VCG *MANUAL Triggering mode Gated mode *External Trigering mode Gated mode *Continuous oscillation available
Frequency	0.01Hz ~ 100kHz	
Range	x0.01, x0.1, x1, x10, x100, x1k, x10k	
Dial Scale	1 ~ 10, equally devided	
Accuracy	$\pm(2\%+0.5\%$ of dial scale)	
Frequency Stability	within $\pm 5\%$ with respect to $\pm 10\%$ fluctuation of power line.	
Output Waveforms	Symmetry waveforms Sine(\sim), Square(\square), Triangular(∇) Unsymmetry Sawtooth(\sphericalangle), (\sphericalcap), Square(\square), (\sqcap)	
Output Voltage	(open circuit) more than 30Vp-p	
Frequency Response	within $\pm 0.3\text{dB}$ with respect to 1kHz	
Output Resistance	$600\Omega \pm 20\%$	
Amplitude Stability	within $\pm 0.5\%$ with respect to $\pm 10\%$ fluctuation of power line voltage	
Output Voltage difference (between waveforms)	Less than 5% at 1kHz	
Distortion (Sine)	Less than 0.6% from 20Hz to 30kHz Less than 1.5% from 30kHz to 100kHz	
DC offset	Less than $\pm 15\text{V}$, (\pm Output Voltage added offset voltage)	
Unsymmetry waveforms	100 times variable at 10 of dial scale (when Range Switch is set on "1 ~ 10k ")	

771314
7

VCG

Control Voltage	Approx. 10mV~10V
Frequency	0.01Hz~100kHz
Range	x1, x10, x100, x1k, x10k
Frequency Variable Range	1:1000 in a Range
Input Resistance	Approx. 10k Ω unbalance
Input Frequency Range	DC~10kHz
Trigger Level	Adjustable within 1Vp-p~ 10Vp-p
Trigger. Slope	+ or - with selector switch
Start-Stop point	variable approx. 0 ~ \pm 90 in sine or triangular wave
Manual trigger	equipped
Sync Signal Output	
Pulse Amplitude	more than -5V peak
Pulse Width	less than 5 μ sec.
Power Source	<u>100</u> V 50/60Hz approx. 9.5VA
Dimensions	138W x 159H x 280D
(Max. Dimensions)	140W x 190H x 340D
Weight	Approx. 3.2kg
Accessories	Operational Manual

3. OPERATION

3-1 Front Panel and Controls (See Fig. 3-1)



1. POWER Power pushbutton switch. when pushed and locked, Power is on and the pilot lamp lights to indicate a ready state

2. MODE A Selection switch of Oscillation Mode. In case of continuous oscillation, the switch is set to "CONT" position. If the equipment is used in gated or triggering mode for generation of pulse or burst waveforms, Set the switch to "EXT TRIG" or "EXT GATE".
For one cycle or manual start oscillation, select a position of "MANUAL TRIG" or "MANUAL GATE"

3. RANGE Selection switch for frequency range Reading value of dial, multiplied by Range multiplier indicates output frequency.
When the dial is used, multiplier from 0.01 to 10k.
In VCG operation multiplier is limited within 1 to 10k.

4. FREQUENCY Frequency variable dial. To turn it clockwise, the frequency increases. When equipment is used as VCG, turn the dial fully counter-clockwise, then VCG function is ready for generation of frequency to be proportional to input applied voltage

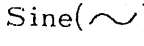
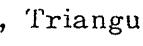
5. FINE Fine frequency adjustment knob. Turning it clockwise, the frequency increases. The dial is calibrated at "CAL'D" position.

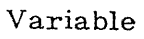
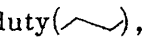
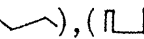
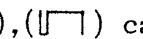
6. FUNCTION Selection switch of waveforms.
Sine() , Triangular() , Square() or Variable duty() , () , () , () can be obtained

771316

9

7. OUTPUT Continuous Variable control knob for the output voltage. Clockwise rotation increases the output voltage, and full-counter-clockwise rotation decrease the output voltage to -20dB. If offset voltage of the output is required. Adjust the output voltage properly with this control. (Dose not use attenuator in offset adjustment)
8. ATTEN An attenuator of the output.
Attenuation of -40dB, -20dB and 0dB can be obtained
9. Output Terminal An output terminal which have output impedance of 600Ω can feed max. 30Vp-p. The outside of BNC receptacle which is connected to signal ground is floated to the case of the equipment.
10. SLOPE CONT A control knob for variable slope triangular waveform and variable duty square waveform.
Turning the knob clockwise, a half period of waveform increases, and ratio would reach to 1:100 at full rotation.
11. DC OFFSET A pushbutton is a switch for ON-OFF OFFSET voltage. A knob under the switch controls continuously OFFSET value from the negative to the positive.
In case of offset voltage applied, a following caution is needed.
Keep the sum of peak output voltage and offset voltage within $\pm 15V$. if not so the output amplifier would saturate and cause excessive distortion.
12. START POINT A control knob for start-stop point of sine and triangular waveform.
If the start-stop point set nearby $+90^\circ$ or more, the equipment will begin to oscillate continuously.
13. TRIG LEVEL Triggering level control knob for triggering or gated oscillation.

77131A

- 14. EXT. TRIG SLOPE A slope selection switch for triggering.
" + " or " - " means positive-going or negative-going respectively.
- 15. MANUAL TRIG A triggering or gate switch for manual operation.
- 16. EXT An external input terminal of triggering. Max. input voltage should be less than 10Vp-p.
- 17. VCG An input terminal of voltage control generator (input voltage controls the frequency).
Acceptable voltage range is from 10mV to 10V

3-2 Rear Panel Description (see Fig.3-2)

- 18. SYNC OUTPUT A synchronization output terminal.
More than -10V peak output signal synchronizing with the positive peak of sine-wave or triangular-wave, or with the fall of square-wave can be obtained.

Synchronize pulse

Sine-wave

Triangular-wave

Square-wave

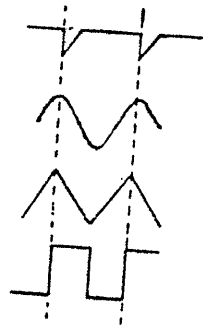

- 19. Fuse A rated 0.5A fuse for AC 100V source
- 20. Power Cord Connected to 50/60 Hz AC source.

771318

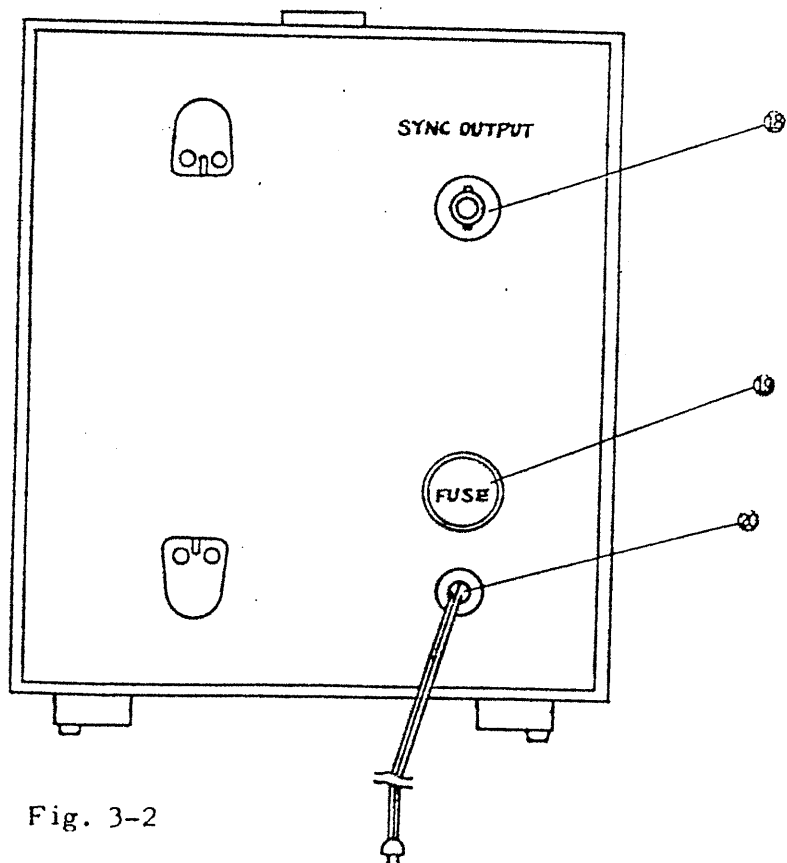
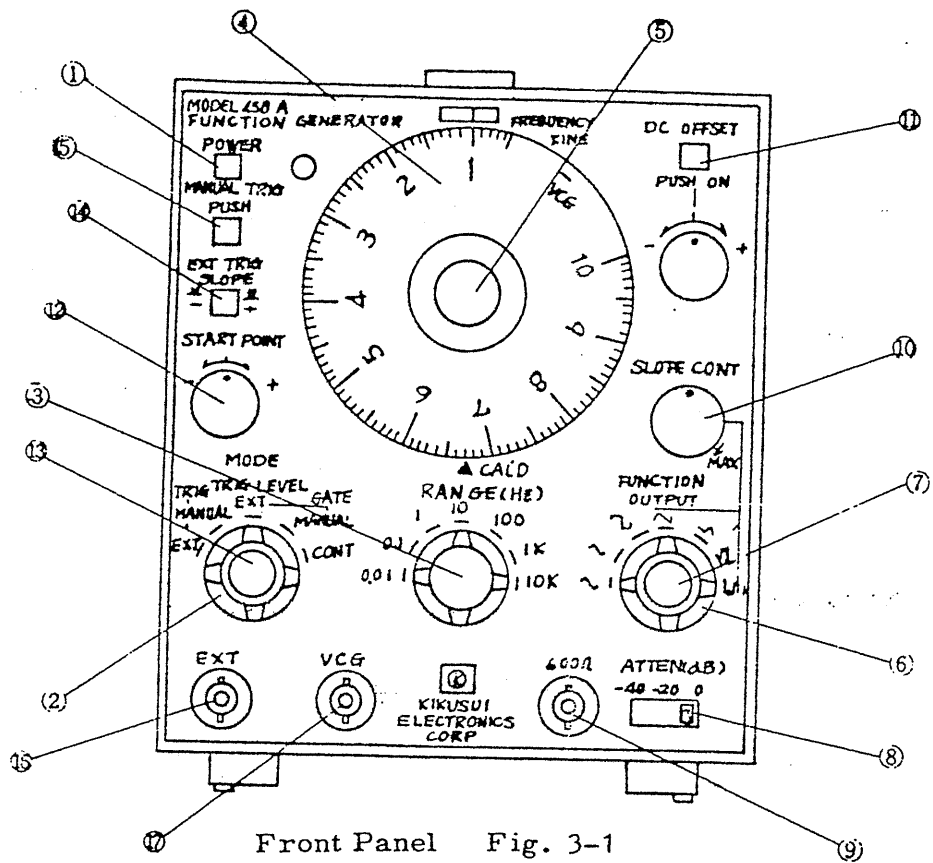

4. PRINCIPLE OF OPERATION

4-1 Fundamental Operation

Fig. 4-1 shows the fundamental block diagram of Model 458A function generator which is composed of a flip-flop circuit, integrator, voltage comparator and sine synthesizing circuit.

When the potential "a" in the flip-flop circuit is $-E$ and the electric charge of capacitor C is zero immediately after power is turned on, the integrated output voltage at point "b" increase in the positive slope. When it reaches $+E_r$, the voltage comparator generates a trigger pulse to invert the flip-flop circuit, causing the potential at point "a" to become $+E$.

Next, the potential at output point "b" of the integrator begins to decrease from $+E$. When it reaches $-E_r$, the voltage comparator generates a trigger pulse to change the flip-flop back to the former. A series of these operational procedures make the oscillation continue.

The oscillation frequency is set by voltage E_r at point "a", setting of R_1 and values of R_2 and C . In general, after approximate oscillation range is set by R_2 and C , the frequency is continuously adjusted by potentiometer R_1 .

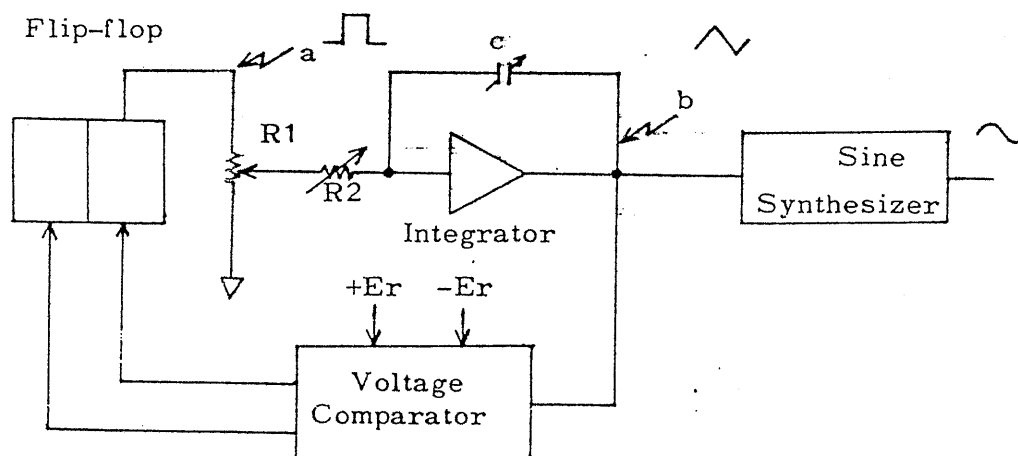

Fig. 4-1

Sine-wave is synthesized from the triangular-wave on integrator output. Fig. 4-2 shows this principle.

Diodes D_1 through D_6 and D_1' through D_6' are connected as shown in Fig. 4-2. All diodes are connected with associated weighted resistors in series in order to obtain the optimum piecewise approximation curve when instantaneous value e of the triangular-wave input is $0 < e < +E_1$, all the diodes are cut off.

771310

13

Therefore, the input waveform appears in the same slope on the output side as it was.

In the case of $+E_1 < e < +E_2$, D_1 becomes conductive and the slope of the output decreases to $R_1/(R_1+R)$ when D_3 through D_6 become conductive by turns, the slope becomes looser.

The negative process is the same as the positive one D_1' through D_6' become conductive by turn and a sine-wave approximating to the pieewise can be obtained on the output side.

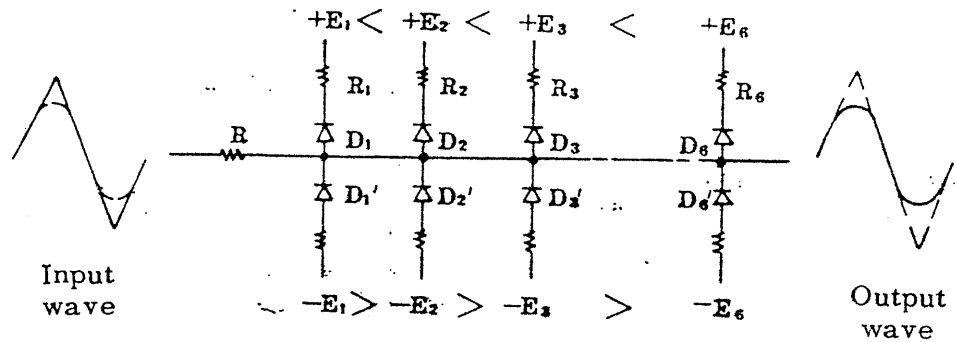

Fig. 4-2

4-2 VCG (VOLTAGE CONTROL GENERATOR) operation

Generators which can control the oscillation frequency by voltage are termed VCG or VCO.

There are the following two methods of voltage control function generators. In one, integrator time constant CR remains constant and the input voltage is controlled.

In the other, a constant current charging capacitor C is controlled.

Model 458 uses the later method (current control system) in order to extend the variable frequency range. Fig. 4-3 shows a block diagram of this method.

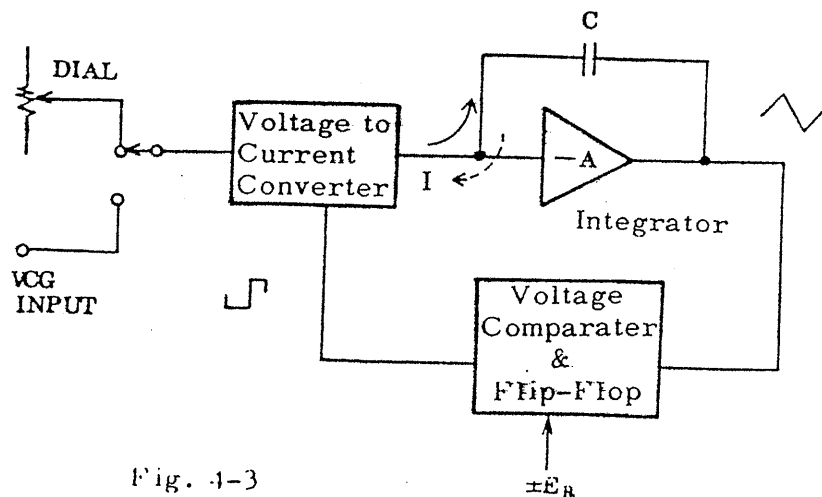

Fig. 4-3

771320
14

When the constant current that is charging capacitor C is expressed as I, and the voltage comparator is set at -E and +E, and time interval t from +E to -E at the output of integrator is set as shown in Fig. 4-4, the following formula (1) can be obtained

$$2Er = \frac{I \cdot t}{C} \dots\dots\dots (1)$$

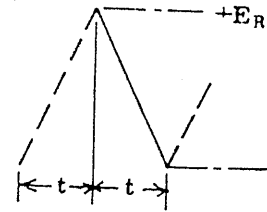

Fig. 4-4

Since oscillation frequency f is $t/2$ as shown in Fig. 4-4, formula (1) is expressed as follows:

$$f = \frac{I}{4ErC} \dots\dots\dots (2)$$

When capacitor C and the reference voltage of the comparator are made constant in formula (2), oscillation frequency f is proportional to the constant current. Thus, it can be controlled by varying the current.

The voltage/current converter converts the input voltage into proportional current to charge integrating capacitor C. Polarity of the current is controlled by the flip-flop circuit to maintain oscillation.

4-3 Slope Control

In section 4-2 charge and discharge current of integrator $|+I|, |-I|$ are both equal. The output is a symmetrical triangular waveform. If one of charge or discharge current is variable, the other fixed, variable slope (when triangular-wave selected) or variable duty (when square-wave selected) can be obtained. Fig. 4-5 shows this principle diagram.

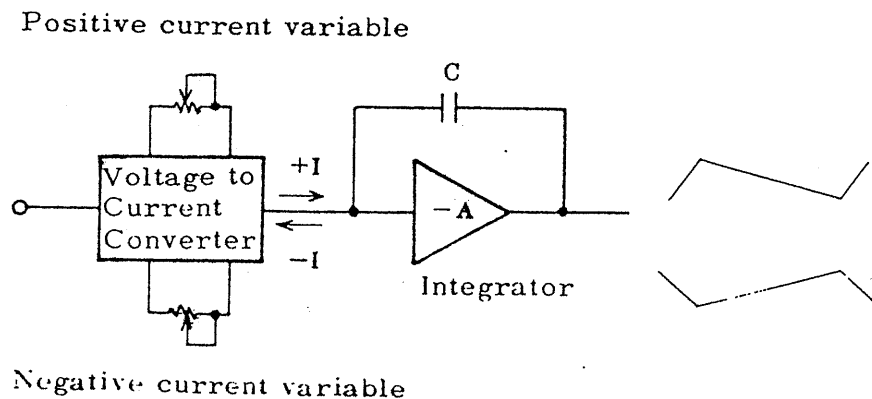

Fig. 4-5

771322

15

1-1 DC offset

As shown Fig.4-6, dc offset voltage is added to the waveforms voltage at the summing point of output amplifier.

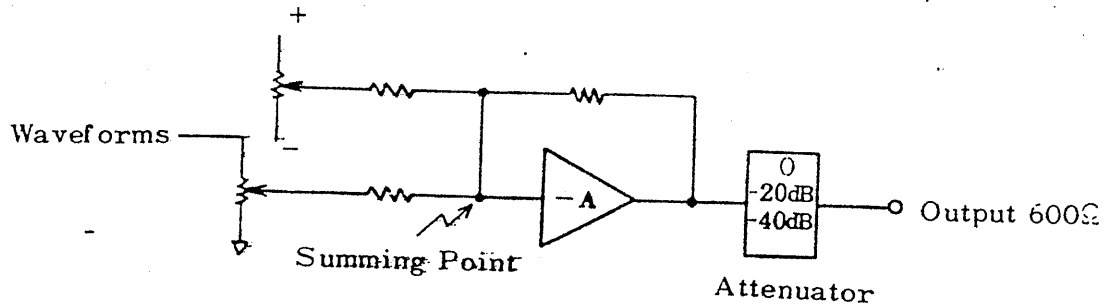

Fig.4-6

4-5 Triggering Oscillation

In this mode, the generator provides only one cycle of oscillation by means of the manual switch or external trigger signal, namely, it performs a mono-stable operation. Fig.4-7 shows the block diagram for triggering oscillation mode.

First, the circuit conditions prior to application of external trigger signal are set as follows;

Output (b) is negative and CR₁ is cutoff and the current polarity of the converter for the flip-flop circuit is set as shown in Fig.4-7

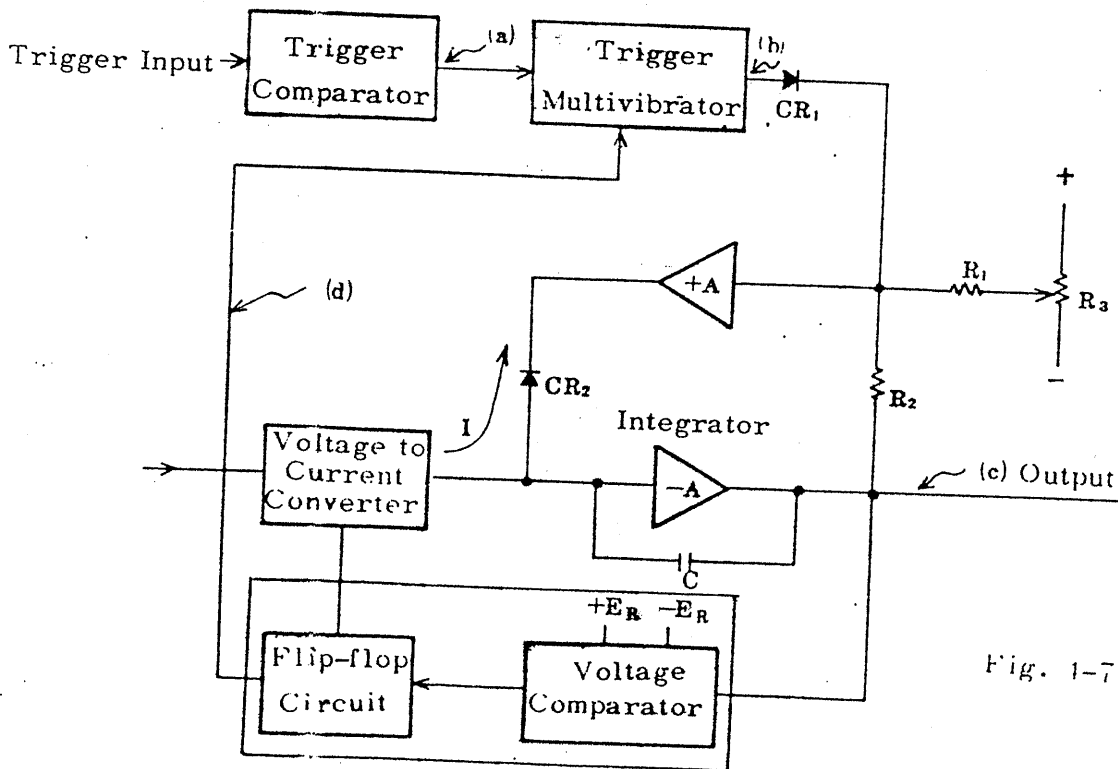

Fig. 1-7

7713228

16

Therefore, CR2 is conducting due to current I. Amplifier $-A$ (integrator) and the non-inverting amplifier $+A$ and R2 compose a closed loop circuit. The potential of output (C) can then be set positively or negatively by optionally setting R3. Whereby the start and stop points of oscillation are also set.

When the trigger signal is applied, the trigger comparator is turned on and generates a trigger pulse to change the state of trigger multivibrator, causing the voltage at (b) to be positive. Diode CR1 then become conductive and the current through $+A$ cuts CR2 off.

The closed loop is then opened and current I starts to charge integrating capacitor C for integration. When output (C) reaches $-E$, the voltage comparator is energized and output (C) begins to increase. When it reaches $-E_r$, the voltage comparator is energized, the state of flip-flop is inverted.

This inverted signal reset the trigger multivibrator to the former state. When output voltage (C) reaches the preset value, $+A$, $-A$ and R2 compose a closed circuit, and thereby oscillation stops. Fig.4-8 shows the relative waveforms in this operational sequence. Fig.4-9 shows the waveforms obtained when start and stop points change.

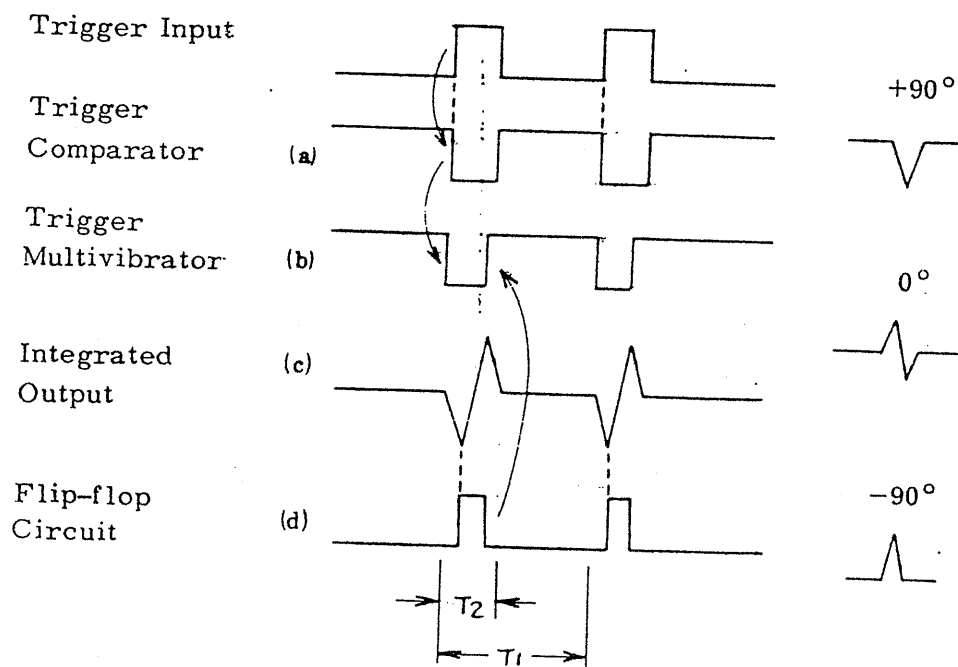

Fig.4-8

Fig. 4-9

Note: T_1 is set by trigger input repetition period.
 T_2 is set by oscillation period.

771324
17

4-6 Gated Oscillation

In the trigger oscillation mode, oscillation is triggered by only one cycle by applying a trigger signal, and it stops until the following trigger is applied.

In the gate oscillation mode, since oscillation is controlled by a gate signal generated in the trigger comparator, a multicycle waveform or tone burst waveform can be obtained.

Fig.4-10 shows the waveforms in every part in the gate oscillation mode. Unlike the trigger oscillation, during the period when output (b) of the trigger comparator is negative, the falling pulse of the flip-flop circuit is gated so that it does not enter the trigger multivibrator.

When the output of the trigger comparator is positive, the gate is opened to reset the trigger multivibrator, causing oscillation to stop. The start and stop points can be varied as with the trigger oscillation mode.

Fig.4-10 shows the waveforms at 0°.

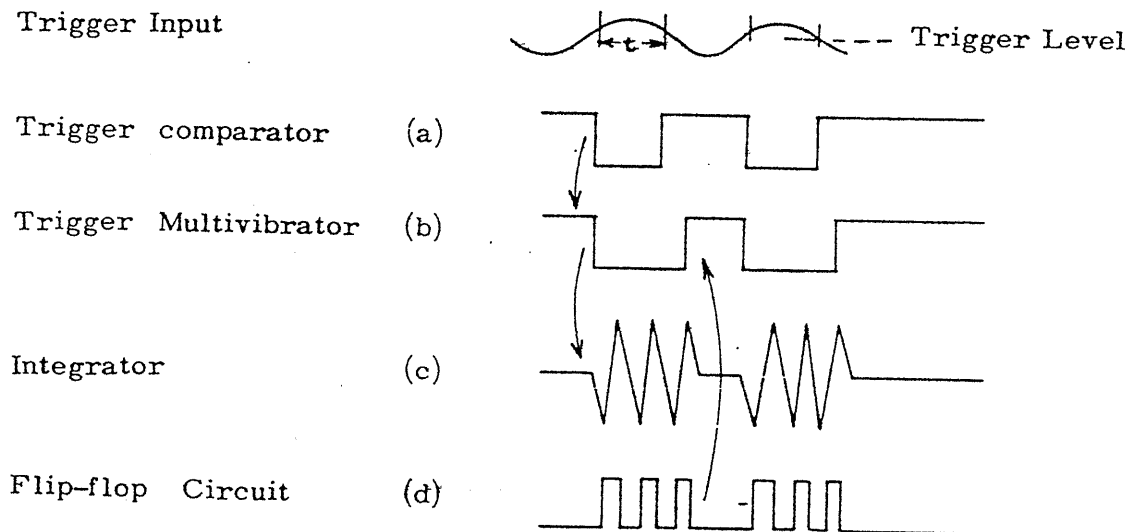

Fig.4-10

When the trigger level is controlled by applying a triangular-wave or sine-wave within a range of ± 1 to $\pm 10V$ to the trigger input terminal, oscillation can be easily varied from one cycle to multicycles.

771325

5. APPLICATION

5-1 In case of linear sweep from 100Hz to 100kHz at rated of 10 periods 1 sec.

Set each control knobs as follows:

- 1) DIAL VCG
- 2) MODE CONT
- 3) VCG INFUT Apply 10Vp-p * sawtooth-wave
- 4) RANGE (100Hz - 100kHz)

* Set the repetition of the sawtooth-wave at 10 sec.

Output waveform
(example of
triangular-wave)

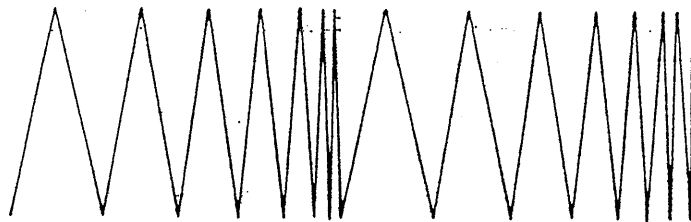

VCG
Input waveform

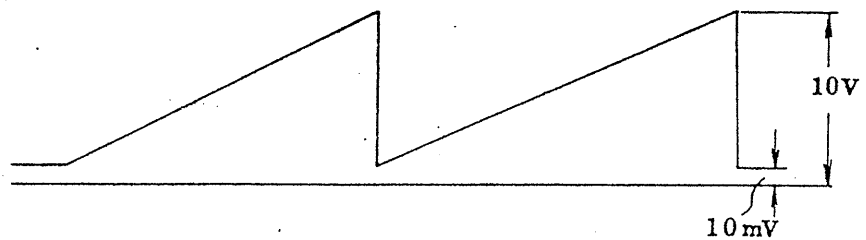

Fig. 5-1

Fig. 5-1 shows a triangular waveform. A sine or square waveform can also be obtained.

7743250

5-2 In case of offset application

(Offset voltage: +10V. output voltage: 10Vp-p. Frequency: 5Hz)

Set each control knobs as follows:

- 1) MODE CONT
- 2) RANGE x1
- 3) DIAL 5
- 4) - FUNCTION
- 5) DC OFFSET ON
- 6) ATTEN 0 dB
- 7) OUTPUT control fully counterclockwise
- 8) connect DC voltmeter to output terminal. and adjust offset control knob to get a reading of +10V.
- 9) Observe the output terminal with an oscilloscope, and adjust output control knob to generate 10Vp-p.

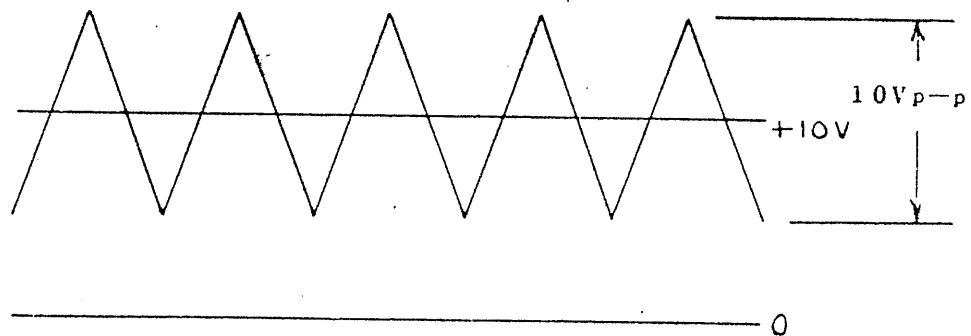

Fig. 5-2

771320
20

5-3 In case of generation of burst waveform

i) To obtain multicycle

Set each knobs as follows;

- | | |
|--------------------------------|---|
| 1) Method of frequency control | DIAL or VCG |
| 2) MODE | GATE (EXT) |
| 3) TRIGGER INPUT | Apply Sine, Square or Triangular waveform
with repetition rate T_1 shown as figure bellow.
(1 ~ 10Vp-p) |
| 4) START/STOP | center position |
| 5) LEVEL | center position |
| 6) SLOPE | (+) or (-) |

Observing the Model 458A output with a oscilloscope, adjust cycle of burst waveform with level control. T_2 in the figure depend upon the dial setting of the Model 458A or input level of VCG.

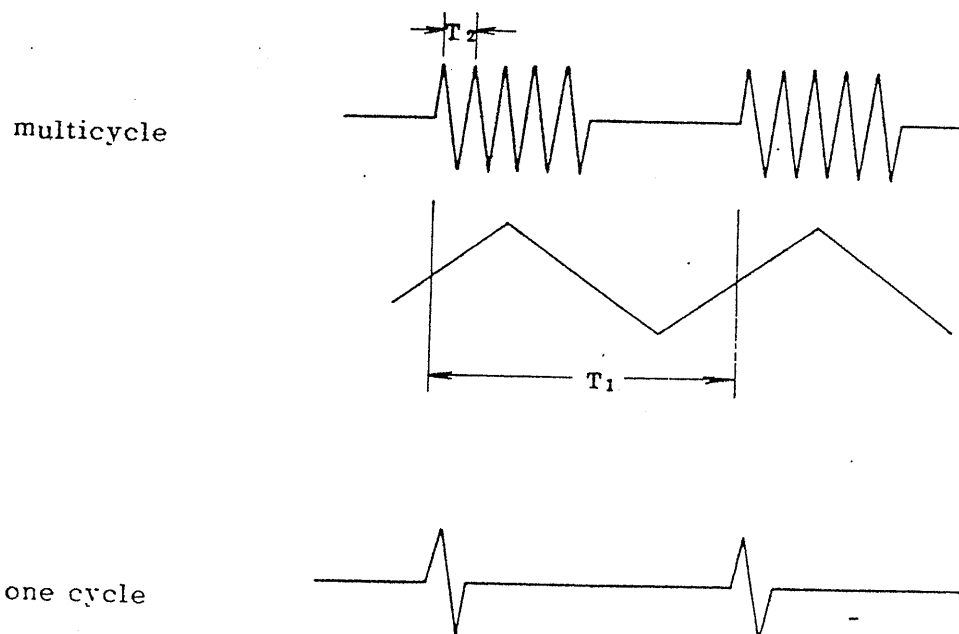

Fig. 5-3

- ii) To obtain one cycle of oscillation, set MODE switch to EXT TRIGGER, the other knobs the same as for multicycle.

6. ARRANGEMENT

Fig. 6-1 shows the arrangement of main parts.

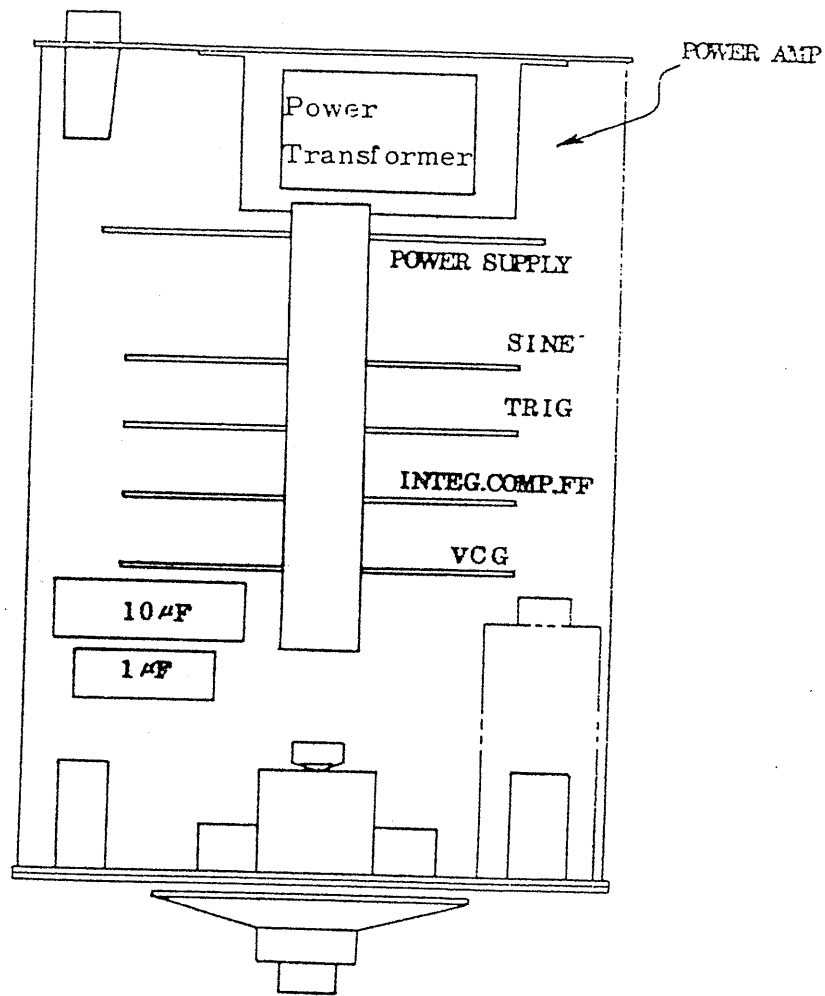

Fig. 6-1